

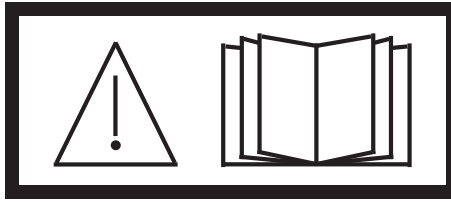

W-500 WELDING TORCH and CW-500 CUTTING ATTACHMENT



Instruction Manual



READ AND UNDERSTAND INSTRUCTION MANUAL BEFORE INSTALLING OR OPERATING. PROTECT YOURSELF AND OTHERS!

CAUTION

These INSTRUCTIONS are for experienced operators. If you are not fully familiar with the principles of operation and safe practices for gas welding and cutting equipment, we urge you to read our booklet, "Precautions and Safe Practices for Gas Welding, Cutting, and Heating," Form F-2035. Do NOT permit untrained persons to install, operate, or maintain this equipment. Do NOT attempt to install or operate this equipment until you have read and fully understand these instructions. If you do not fully understand these instructions, contact your supplier for further information. Be sure to read the Safety Precautions before installing or operating this equipment.

USER RESPONSIBILITY

This equipment will perform in conformity with the description thereof contained in this manual and accompanying labels and/or inserts when installed, operated, maintained and repaired in accordance with the instructions provided. This equipment must be checked periodically. Malfunctioning or poorly maintained equipment should not be used. Parts that are broken, missing, worn, distorted or contaminated should be replaced immediately. Should such repair or replacement become necessary, the manufacturer recommends that a telephone or written request for service advice be made to the Authorized Distributor from whom it was purchased.

This equipment or any of its parts should not be altered without the prior written approval of the manufacturer. The user of this equipment shall have the sole responsibility for any malfunction which results from improper use, faulty maintenance, damage, improper repair or alteration by anyone other than the manufacturer or a service facility designated by the manufacturer.

IMPORTANT SAFEGUARDS

When using Oxy-Fuel Gas Torches, basic safety precautions should always be followed:

- a. Never use Acetylene gas at a pressure over 15 psig.
- b. Never use damaged equipment.
- c. Never use oil or grease on or around Oxygen equipment.
- d. Never use Oxygen or fuel gas to blow dirt or dust off clothing or equipment.
- e. Never light a torch with matches or a lighter. Always use a striker.
- f. Always wear the proper welding goggles, gloves and clothing when operating Oxy-Acetylene equipment. Pants should not have cuffs.
- g. Do not carry lighters, matches or other flammable objects in pockets when welding or cutting.
- h. Always be aware of others around you when using a torch.
- i. Be careful not to let welding hoses come into contact with torch flame or sparks from cutting.
- j. **SAVE THESE INSTRUCTIONS.**

**BE SURE THIS INFORMATION REACHES THE OPERATOR.
YOU CAN GET EXTRA COPIES THROUGH YOUR SUPPLIER.**

SAVE THESE INSTRUCTIONS!

SAFETY PRECAUTIONS

WARNING

These Safety Precautions are for your protection. They summarize precautionary information from the references listed in Additional Safety Information section. Before performing any installation or operating procedures, be sure to read and follow the safety precautions listed below as well as all other manuals, material safety data sheets, labels, etc. Failure to observe Safety Precautions can result in injury or death.



PROTECT YOURSELF AND OTHERS - Some welding, cutting and gouging processes are noisy and require ear protection. Hot metal can cause skin burns and heat rays may injure eyes. Training in the proper use of the processes and equipment is essential to prevent accidents. Also:

1. Always wear safety glasses with side shields in any work area, even if welding helmets, face shields, or goggles are also required.
2. Wear flameproof gauntlet type gloves, heavy long-sleeve shirt, cuffless trousers, high-topped shoes, and a welding helmet or cap for hair protection, to protect against hot sparks and hot metal. A flameproof apron may also be desirable as protection against radiated heat and sparks.
3. Hot sparks or metal can lodge in rolled up sleeves, trousers cuffs, or pockets. Sleeves and collars should be kept buttoned, and open pockets eliminated from the front of clothing.
4. Protect other personnel from hot sparks with a suitable non-flammable partition or curtains.
5. Use goggles over safety glasses when chipping slag or grinding. Chipped slag may be hot and can travel considerable distances. Bystanders should also wear goggles over safety glasses.



FIRES AND EXPLOSIONS - Heat from a flame can act as an ignition source. Hot slag or sparks can also cause fires or explosions. Therefore:

1. Remove all combustible materials well away from the work area or completely cover the materials with a protective non-flammable covering. Combustible materials include wood, cloth, sawdust, liquid and gas fuels, solvents, paints and coatings, paper, etc.
2. Hot sparks or hot metal can fall through cracks or crevices in floors or wall openings and cause a hidden smoldering fire on the floor below. Make certain that such openings are protected from hot sparks and metal.
3. Do not weld, cut, or perform any other hot work on materials, containers, or piping until it has been completely cleaned so that no substances on the material can produce flammable or toxic vapors. Do not do hot work on closed containers. They may explode.
4. Have fire extinguishing equipment handy for instant use, such as a garden hose, a pail of water or sand, or portable fire extinguisher. Be sure you are trained in its use.
5. After completing operations, inspect the work area to be sure that there are no hot sparks or hot metal which could cause a later fire. Use fire watchers when necessary.
6. For additional information, refer to NFPA Standard 51B, "Fire Prevention in Use of Cutting and Welding Processes", which is available from the National Fire Protection Association, Batterymarch Park, Quincy, MA 02269.



FUMES AND GASES - Fumes and gases, particularly in confined spaces, can cause discomfort or injury. Do not breathe fumes or gases from welding or cutting. Therefore:

1. Always provide adequate ventilation in the work area by natural or mechanical ventilation means. Do not weld, cut, or gouge on materials such as galvanized steel, stainless steel, copper, zinc, lead, beryllium, or cadmium unless positive mechanical ventilation is provided. Do not breathe fumes and gases from these materials.
2. If you develop momentary eye, nose, or throat irritation while operating, this is an indication that ventilation is not adequate. Stop work at once and take necessary steps to improve ventilation in the work area. Do not continue to operate if physical discomfort persists.

3. Refer to ANSI/ASC Standard Z49.1 listed below for specific ventilation recommendations.

4. **WARNING:** This product, when used for welding or cutting, produces fumes or gases which contain chemicals known to the State of California to cause birth defects and, in some cases, cancer. (California Health & Safety Code §25249.5 et seq.)



EQUIPMENT MAINTENANCE - Faulty or improperly maintained equipment, such as torches, hoses and regulators, can result in poor work, but even more important, it can cause injury or death through fires. Therefore:

1. Always have qualified personnel perform the installation, troubleshooting, and maintenance work. Do not operate or repair any equipment unless you are qualified to do so.
2. Keep all oxy-fuel equipment free of grease or oil. Grease, oil, and other similar combustible materials, when ignited, can burn violently in the presence of oxygen.
3. Do not abuse any equipment or accessories. Keep equipment away from heat and wet conditions, oil or grease, corrosive atmospheres and inclement weather.
4. Keep all safety devices in position and in good repair.
5. Use equipment for its intended purpose. Do not modify it in any manner.



GAS CYLINDER HANDLING - Gas cylinders, if mishandled, can rupture or explode violently. Sudden rupture of a cylinder, valve or relief device can injure or kill you. Therefore:

1. Use the proper gas for the process and use the proper pressure reducing regulator designed to operate from the compressed gas cylinder. Do not use adaptors to mount the regulator on the cylinder. Maintain hoses and fittings in good condition. Follow manufacturer's operating instructions for mounting the regulator to the gas cylinder.
2. Always secure cylinders in an upright position by chain or strap to suitable hand trucks, benches, walls, post, or racks. Never secure cylinders to work tables or fixtures where they may become part of an electrical circuit.
3. When not in use, keep cylinder valves closed. Have the valve protection cap in place on top of the cylinder if no regulators is installed. Secure and move cylinders by using suitable hand trucks. Avoid rough handling of cylinders.
4. Locate cylinders away from heat, sparks, or flame of a welding, cutting, or gouging operation. Never strike an arc on a cylinder.
5. For additional information, refer to CGA Standard P-1, "Precautions for Safe Handling of Compressed Gases in Cylinders", which is available from the Compressed Gas Association, 1235 Jefferson Davis Highway, Arlington, VA 22202.



ADDITIONAL SAFETY INFORMATION - For more information on safe practices for oxy-fuel welding and cutting equipment, ask your distributor for a copy of "Precautions and Safe Practices for Gas Welding, Cutting, and Heating", Form 2035. Gas apparatus safety guidelines are also available on video cassettes from your distributor.

The following publications, which are available from the American Welding Society, 550 N.W. LeJuene Road, Miami, FL 33126, are recommended to you:

1. ANSI/AWS Z49.1 - "Safety in Welding and Cutting".
2. AWS F4.1 - "Recommended Safe Practices for the Preparation for Welding and Cutting of Containers and Piping That Have Held Hazardous Substances".
3. AWS SP - "Safe Practices" - Reprint, Welding Handbook.



MEANING OF SYMBOLS - As used throughout this manual: Means Attention! Be Alert! Your safety is involved.



Means immediate hazards which, if not avoided, will result in immediate, serious personal injury or loss of life.



Means potential hazards which could result in personal injury or loss of life.



Means hazards which could result in minor personal injury.

OXWELD® CW-500 Cutting Attachment



Cutting Range using acetylene..... 1/16 to 8 in.
 Cutting Range using other fuel gases 1/16 to 4 in.
 Cutting Nozzles 1500 series
 Length..... 11-in.
 Weight 1-1/2 lb.



CW-500 Cutting Attachment
 (90 deg. Head) - P/N 999220
 (75 deg. Head) - P/N 16581

- Ease-on control of cutting oxygen flow for smoother starts
- Medium-pressure operation with any fuel gas
- Cuts up to 8 in. thick steel using acetylene – also effective for pad washing, gouging, and rivet washing
- Extra length Teflon valve packing for improved preheat oxygen valve control
- Flip-over cutting lever for easier connection
- Nickel silver tubes for strength and cooler operation

Accessory: Quick-closing Oxygen Shut-off Valve, P/N 999306.
 Particularly recommended when using the No. 300 O-FG or No. 500 O-FG Rosebud Heating Head. Connects between torch and oxygen hose for quickly shutting off oxygen flow in the event of flashback.

OXWELD® W-500 Torch

Welding Range Thin gauge to 1 in.
 Heating Range..... up to 300 cfh acetylene
(441,000 Btu/hr.)*
 Length..... 8-1/2-in.
 Weight 1-1/4 lb.
 Torch-Hose Connections Oxy - CGA-022 (9/16"-18)
 F.G. - CGA-023 (9/16"-18 LH)

*Acetylene and other fuel gases may be used. A No. 500 Rosebud heating head (see below) is available.



W-500 Welding Torch
 P/N 999079

- Wide range, high capacity – many welding and heating heads available for everything from welding gauge material to heating steel plates requiring 735,000 btu/hr.
- Medium-pressure operation – can be used for acetylene and other fuel gases
- O-ring seals – head and cutting attachment connecting nut require hand tightening only
- Permanently stamped identification – will not wear off – no decal or label to peel off
- Extra-long Teflon valve packing for improved backlash characteristics
- Durability – built for rugged performance and long life



W-500 Acetylene Welding Heads
 (Single Flame)



W-500 Standard
 Multiflame Heating Heads



W-500 Rosebud Style Multiflame
 Heating Heads

Welding and Heating Head Extensions for W-300, -400, -500, -17
 Permit working at a comfortable distance from heat during heavy welding and heating jobs.



OPERATING INSTRUCTIONS

NOTE: The W-500 is supplied so that the head connecting nut (136Z13 - see Fig. 1) can be removed from the torch handle. This permits connecting a No. 300 O-FG or No. 500 O-FG Rosebud heating head, both of which are equipped with a captive nut. If desiring to make the 136Z13 nut captive on the torch and if you do not intend to use either No. 300 or No. 500 head, assemble retaining spring (93Z23 - supplied with the torch) to the nut as illustrated in Fig. 1.

CONNECTING

1. Attached regulators to the oxygen and fuel gas cylinders. Follow all instructions supplied with your regulators.
2. Attach oxygen and fuel gas hoses (see Note 1 in Operating Data section on page 3 for recommended hose sizes) to the regulator and to the torch handle, after making sure all metal seating surfaces are clean. Tighten all connecting nuts with a wrench.
3. Referring to Fig. 1, loosen the torch locking nut (136Z13) by turning counterclockwise at least one full turn or until the internal garter spring (29Z60) has expanded completely. Insert the welding or heating head or CW-500 cutting attachment by pushing and turning back and forth simultaneously until it is fully seated. Lock the head or cutting attachment in place by hand tightening the lock nut.
If the groove about the mixer tube part of the welding or heating head is visible after locking, the head is NOT fully seated. Correct and make sure this groove is NOT visible before proceeding to the next step. (See Fig. 2 for location of groove.)
4. If using the CW-500, remove nozzle nut and insert cutting nozzle into the cutting attachment head. Slip nut over the nozzle and tighten with a wrench.
5. Check throttle valve packing nuts for tightness.



WARNING



Flashbacks can cause serious burns.

Be sure gas flow is sufficient for head or nozzle size.

Adjust regulators for proper psig pressures. Adjust throttle valves properly. Keep torch in good repair. DO NOT throttle back gases to use large head or nozzle on thin material.

ADJUSTING GAS PRESSURES

Fuel Gas: With oxygen valve closed, open the fuel gas valve on the torch handle about one turn. Turn in the pressure-adjusting screw on the fuel gas regulator until its delivery-pressure gauge indicates the desired pressure (refer to operating tables starting on page 4). Then immediately close the torch fuel gas valve.

Oxygen, Using Welding or Heating Head: Open the torch oxygen valve at least 1-1/2 turns. Adjust oxygen pressure at the regulator to the desired pressure (refer to Table 2, 3, or 4) and then close the torch oxygen valve.

Oxygen, Using Cutting Attachment: Open the torch oxygen valve WIDE and leave the preheat oxygen valve on the cutting attachment closed. Depress the cutting oxygen valve lever on the cutting attachment. Adjust the oxygen pressure at the regulator to the desired pressure (refer to Table 5 or 6). Shut off the oxygen flow by releasing the cutting oxygen valve lever only.

TESTING FOR LEAKS

Every welding and cutting outfit should be thoroughly tested for leaks after it is first hooked up, and at regular intervals thereafter. After all connections have been made, make sure both valves on the torch handle are closed. Then turn in the regulator pressure-adjusting screws clockwise until the oxygen delivery-pressure gauge registers 50 psi, the full gas delivery-pressure registers 10 psi. Using Leak Test Solution suitable for oxygen service, such as P/N 998771 (8 oz. container), check for leaks at the cylinder valves, the cylinder-to-regulator connections, the regulator-to-hose connections, and the hose-to-torch connections. If bubbling at any point indicates leakage, tighten the connection. If this does not stop the leakage, close the appropriate cylinder valve, open the torch valve to remove all pressure from the line, and finally release the regulator pressure-adjusting screw by turning it counterclockwise. Then break the leaky connections, wipe metal seating surfaces with a clean, dry cloth, and examine them for nicks and scratches. Remake the connection(s) and retest. Do not try to light the torch until you are satisfied that all connections are gas-tight.

LIGHTING & FLAME ADJUSTMENT

CAUTION: Use friction lighter for lighting torch. Do NOT use a match. Use of a match can seriously burn your hand.

Welding or Heating Head (Acetylene)

1. Open fuel gas valve about 1/2 turn and light the gas at the tip.
2. Slowly close the fuel gas valve until the yellow flame just starts to throw off smoke.
3. Open oxygen valve slowly until you have a neutral flame.
4. If harsher or softer flame is desired, readjust the two valves.

NOTE: When operating with a very soft flame, the welding head will tend to heat up and transfer some of this heat back to the torch handle. This may create some discomfort to the operator.

Heating Head (Fuel Gases except Acetylene)

1. Crack fuel gas valve and light the gas at the tip.
2. Open fuel gas valve until flames start to leave end of tip.
3. Slowly open oxygen valve until flames are at their shortest lengths.
4. If necessary, alternately open fuel gas and oxygen valves to the desired flame size.

Cutting Attachment (Acetylene)

1. Open the acetylene valve on the torch handle about 1/2 turn, and light the gas at the nozzle.
2. Slowly close the acetylene throttle valve until the yellow flame just starts to throw off black smoke.
3. Slowly open preheat oxygen valve on cutting attachment until neutral flames are obtained.
4. Finally, open the cutting oxygen valve by depressing lever and readjust for neutral flames by turning preheat oxygen valve.

The flame now has the proper strength for any cutting job. With this flame, acetylene is being consumed economically and the cutting attachment will be operating at best resistance to flashback. If greater preheat flame temperature is desired for faster starts or piercing, open the cutting oxygen valve and adjust the preheat oxygen valve until the flame inner cones shorten about 10 percent and become sharply pointed.

Cutting Attachment (Fuel Gases except Acetylene)

1. Crack the fuel gas valve and light the gas at the nozzle.
2. Open fuel gas valve until flame starts to leave the end of the nozzle.
3. Slowly open preheat oxygen valve on cutting attachment until flame stabilizes.
4. Depress lever to open cutting oxygen valve and then adjust preheat oxygen valve until preheat flames are at their shortest length.
5. If larger or smaller preheat flames are desired, depress cutting oxygen valve lever and alternately readjust fuel gas and preheat oxygen valve to obtain the final flame setting.

SHUTTING OFF

Close the fuel gas valve first, then the oxygen valve whether you are using a welding head or cutting attachment. However, if the cutting attachment is to be relighted within a half-hour, you may close the preheat oxygen valve on the attachment instead of the oxygen valve on the torch handle.

If operations are to be stopped for a half-hour or more, you should release all pressure from regulators. To do this, first close both cylinder valves. Then open the torch valves. Finally, back out the regulator pressure-adjusting screws until they turn freely.

OPERATING PRECAUTIONS

Do not exceed 15 psig acetylene during operation.

Flow: There must be proper flow of gases for safe operation and full performance. This requires the following three conditions: (1) the regulators that determine the inlet pressure to the hoses must be set to the correct pressure; (2) the hoses and their connectors must have adequate capacity for the job (hoses that are too long, too small or have connectors with small passageways can cause problems); and (3) the throttle valves on the torch must be adjusted with the procedure shown in these instructions.

Note: Items (1) and (2) can be checked by measuring the gas pressures at the torch. Gauge adaptors are available for this purpose.

Backfire: Improperly operating of the torch or cutting attachment may cause the flame to go out with a loud "pop". (If you are welding, the flame will often reignite instantly.) Such a backfire may be caused by contact of tip or nozzle with the work, by spatter from the work, by the use of incorrect gas pressures, or by leakage at the cutting nozzle seats due to dirt or nicks on seats or to a loose nozzle nut. After a backfire, you can normally relight the flames immediately, however, if backfires occur repeatedly, shut off the torch. Check the 'O'-ring seals between the welding head or cutting attachment and the handle, and the nozzle seats (if cutting). Readjust operating pressures and relight.

Flashback: Under certain exceptional circumstances, the flame may not 'pop' out (backfire) but instead burn back inside the torch with a shrill hissing or squeal. This is called a 'flashback'. A flashback should never occur if (1) the equipment is in good condition; (2) preheat ports on cutting nozzles or welding tips are cleaned frequently; (3) operating pressures are correct; and (4) throttle valves are adjusted properly. Should a flashback occur, IMMEDIATELY shut off the torch. Allow it to cool off from at least a minute. Then check your nozzle or tip, gas pressures, readjust regulators if necessary, and relight the torch. If flashback recurs, send the torch handle and welding head or cutting attachment to your distributor for repair.

OPERATING DATA

General Notes:

1. Pressures give in Tables 2 through 6 are measured at the regulator using 25-ft. long hoses (1/4-in. I.D. up through size No. 30 welding/heating head or for cutting up to 3-in. thick steel; 3/8-in. I.D. for larger heads or cutting nozzles). If longer hoses are required, only 3/8-in. I.D. hoses should be used and pressure drop between regulator and torch should be considered.
2. Head size number on each welding and heating head indicates the rated acetylene flow capacity in cubic feet/hour (cfh). For example, No. 55A requires about 55 cfh of acetylene at the given operating pressures. However, on heating heads designed for other fuel gases, the size indicates the approximate equivalent heating capacity in terms of acetylene flow. For example, note from Table 3 that No. 100A and No. 100FG provide the same average heating output (147,000 Btu/hr) but No. 100FG head really requires about 62 cfh of FG-2, 57 cfh of propane, or 147 cfh of natural gas.

For consumption purposes, the following are the oxygen/fuel gas ratios normally required for welding and heating:

- 1.1 to 1.5 cfh oxygen/1.0 cfh acetylene
- 3.2 to 3.6 cfh oxygen/1.0 cfh FG-2
- 3.5 to 4.5 cfh oxygen/1.0 cfh propane
- 1.7 to 2.0 cfh oxygen/1.0 cfh natural gas

3. Correct pressure and flow must be maintained for proper operation of a welding or heating head. If a trip is "starved" due to insufficient flow of fuel gas, the tip may overheat and cause backfire or flashback.

An acetylene or a liquefied fuel gas (LFG) cylinder has a limited capacity for delivering fuel to the tip, therefore, it is extremely important to manifold 2 or more cylinders when operating larger heads to assure adequate supply of fuel gas to the tip. The rate of withdrawal depends on type of fuel gas cylinder size, the contents remaining, and the outside temperature. Tabulated below is the number of the more commonly used cylinders recommended for manifolding when using larger heads. If using other cylinders or gases, check with your fuel gas supplier for recommended withdrawal rate information.

4. For safe and reliable operation when using large heating heads (particularly No. 300 O-FG and No. 500 O-FG Rosebud heating heads), the following conditions are strongly recommended:
 - a. Connect quick-closing shutoff valve at the torch oxygen connection.
 - b. Use 3/8-in. hose with 1/4-in. I.D. hose nipples.
 - c. Keep torch oxygen and fuel gas valves fully open.
 - d. Do not use hose line check valves. They will restrict the flow.
5. All welding and heating heads and CW-500 cutting attachment can be used with the old W-47 torch EXCEPT the No. 300 FG and No. 500 O-FG Rosebud heating heads. The W-47 can restrict the flow of the oxygen and fuel gas enough to overheat and possibly damage the tip.
6. Tables 5 and 6 show average values based on typical conditions. The type and quality of steel, its surface condition, the purity of oxygen, etc., will always have a bearing on the end results.

MAINTENANCE INSTRUCTIONS

For all repairs other than those covered below, send the torch to your distributor or to ESAB Remanufacturing Center, 411 S. Ebenezer Road, Florence, SC 29501. Improperly repaired apparatus is hazardous.

Torch Handle and Cutting Attachment Throttle Valves - Leakage around throttle valve can almost always be corrected by tightening the packing nut slightly. If necessary, replace the complete throttle valve assembly as directed below. If a valve will not shut off completely, loosen the packing nut and unscrew the throttle valve assembly from the body. Wipe the stainless steel ball seat on the valve stem, and the seating surface in the body, with a clean cloth. Then reinstall the valve, retighten the packing nut, and operate the valve several times, closing it with maximum force. If this does not end the leakage, install a new throttle valve assembly. When you do so, tighten the packing nut until you find it extremely difficult to turn the valve wheel. Set the unit aside for a few hours to set the packing. Then loosen the packing nut until the throttle valve turns easily.

Cutting Valve - If leakage is detected around the cutting oxygen valve of cutting attachment, or if the valve does not shut off completely when cutting oxygen valve lever is released, unscrew the lock screw (57K02) with a spanner wrench. When the thread is fully disengaged, lift out the valve assembly. Then tilt the attachment and let the valve spring drop out in your hand.

Now pull the lock screw off the valve stem and remove seat and retainer from the stem. Examine the stem carefully. If either the seating surface or the cylindrical section that runs in the valve screw is marred, replace the stem with a new part. Always replace the seat with a new part. Replace the small 'O'-ring in the lock screw with a new part if there has been leakage around the valve stem. Inspect the large 'O'-ring and replace it if it is not in excellent condition. Place new seat on stem, slide on the retainer, and insert stem

Head Size	FG-2 (104 lb. cyl.)		Propane (100 lb. of cyl.)	
	Flowrate	Min. No. of Cyl. Req'd*	Flowrate	Min. No. of Cyl. Req'd**
70	43	1	40	1
100	62	1	58	1
150	93	1	86	2
200	124	2	116	2
300	186	2	174	3
500	310	3	290	5

* Based on max. continuous withdrawal rate of 110 cfh for 104 lb. cylinder, 1/2 full @ 70° F.

** Based on max. continuous withdrawal rate of 65 cfh for 100 lb. cylinder, 1/2 full @ 70° F. Withdrawal rate will increase with wind velocity and intermittent usage; reduce with lower temperature.

in lock screw (be sure the lock screw has both 'O'-rings in position). Finally, slide valve spring into body, insert valve assembly, and tighten lock screw.

Cutting Attachment Mixer - To remove the mixer for cleaning or replacement, back off locknut (56K07) until it reaches the end of the threads on the adaptor (19K07). Continue turning it, with a wrench, to unscrew the adaptor from the attachment body. Then remove the mixer by grasping the end of the mixer carefully with a pair of pliers and pulling it out. Clean mixer center orifice with a No. 55 cleaning drill and the cross-drillings with a No. 66 drill, or soak the mixer overnight in a solution of OXWELD Nozzle Cleaning Compound (P/N 761F00), rinse, and blow dry with clean air.

Inspect all 'O'-rings and replace them if they are not in good condition. Reassemble in reverse order, and tighten locknut against body securely.

Welding Heads and Cutting Nozzles - Welding heads and cutting nozzle orifices should be cleaned by hand, using OXWELD tip cleaners, whenever a flame distortion is noticed. Maintaining clean orifices is highly recommended for reducing any incidence of flashbacks. If you do not have tip cleaners, twist drills of the correct sizes (see Tables) may be used. Insert the drill carefully, and push it back and forth. DO NOT TWIST THE DRILL.

If a welding tip requires replacement, secure the front end of the mixer throat in a vise and unscrew the tip. Before installing a new tip, be sure it matches the mixer throat in size (both parts are size-stamped). Always tighten the new tip as much as you can without bending it.

To clean a welding head mixer, unscrew it from the mixer throat, soak it overnight in a solution of OXWELD Nozzle Cleaning Compound, rinse with clear water, dry with a jet of air.

Check the condition of 'O'-rings on the welding heads periodically. If they appear to be in poor condition, or are so worn that the head can be inserted in the handle without noticeable resistance, replace them.

Head Size	Flowrate, cfh	Min. No. of Cylinders Required*	
		WK Cyl. (300 cf)	WLT Cyl. (390 cf)
55	55	2	1
70	70	2	2
100	100	3	2
150	150	4	3
200	200	5	4
250	250	6	5
300	300	7	6

* Based on that max. hourly flowrate should not exceed 1/7 of cylinder capacity at 70° F. Example 1/7 (300 of WK cyl.) = 43 cfh max.

Table 2 - W-500 Acetylene Welding Heads (Single - Flame)

Complete Head Assembly		Steel Thickness, in.	Pressure, psig		Replacement Parts (See Fig. 2)			Accessory Tip Extension	Tip Cleaning Drill Size
Size	Part No.		Oxygen	Acetylene	Tip	Mixer Tube	Mixer		
4A	639880	25 ga.-3/32			639684	639878	02Z53	----	64
6A	639881	1/32 - 1/16			639685	639878	02Z54	----	62
9A	639882	1/16 - 1/8	5 - 8	5 - 8	639686	639878	02Z55	----	55
15A	639883	1/8 - 3/16			639687	639878	02Z57	----	53
30A	20336	3/16 - 3/8			17261	20337	639973	----	45
55A	998115	3/8 - 5/8	5 - 8	5 - 8	998060	116Z04	02Z61	19X42 (12")	33
70A	998116	5/8 - 1			998061		02Z62	19X42 (12")	30
100A	10X64	over 1	7 - 10	5 - 8	998062	116Z06	02Z64	19X43 (15")	25
150A	10X68		12 - 15	6 - 8	64Z22	116Z08	02Z66	19X44 (18")	17
300A	10X76	Heating	28 - 32	10 - 12	64Z30	116Z12	02Z69	19X45 (21")	1/4"

Table 3 - W-500 Standard Multiflame Heating Heads

Complete Head Assembly		Pressure, psig		No. of Flames	Avg. Heat Output Btu/hr.	Replacement Parts (See Fig. 2)			Accessory Tip Extension	Tip Cleaning Drill Size
Size	Part No.	Oxy.	Fuel Gas			Tip	Mixer Tube	Mixer		
For Oxy-Acetylene Use										
100A	10X86	8 - 10	6 - 8	8	147,000	998072	116Z06	02Z64	19X43 (15")	55
150A	10X88	12 - 15	7 - 10	12	220,000	998073	116Z08	02Z66	19X44 (18")	55
300A	10X91	30 - 34	11 - 14	24	441,000	12Y45	116Z12	02Z69	19X45 (21")	55
For Oxy-Fuel Gas Use - FG-2, propane, natural gas, etc.										
100FG	11X03	11 - 14	10 - 12	8	147,000	998079	116Z06	02Z93	19X43 (15")	48
150FG	11X05	21 - 24	11 - 13	12	220,000	998036	116Z08	02Z95	19X44 (18")	48
300FG	11X08	48 - 52	20 - 22	24	441,000	12Y61	116Z12	02Z89	19X45 (21")	48

Table 4 - W-500 Rosebud Style Multiflame Heating Heads

Complete Head Assembly		Pressure, psig			No. of Flames	Avg. Heat Output Btu/hr.	Replacement Parts (See Fig. 2)			Tip Extension (Accessory)		Tip Cleaning Drill Size
Size	Fuel Part No.	Oxy.	Fuel Gas	Tip Assy.			Stem	Mixer Tube	Mixer	Length	P/N	
For Oxy-Acetylene Use												
55 O-A	998833	6 - 8	4 - 6	9	81,000	998797	998792	116Z04	02Z61	12-in.	19X42	61
70 O-A	998834	7 - 9	5 - 7	9	103,000	998798	998792	116Z04	02Z62	12-in.	19X42	57
100 O-A	998835	8 - 12	5 - 7	13	147,000	998779	998793	116Z06	02Z64	15-in.	19X43	57
200 O-A	998836	14 - 19	9 - 11	16	294,000	998800	998794	116Z08	998788	18-in.	998790*	54
For Oxy-Fuel Gas Use - FG-2, propane, natural gas, etc.												
250 O-A	998837	18 - 24	9 - 11	16	368,000	998827	998826	116Z12	998789	21-in.	998825*	53
100 O-FG	999235	17 - 22	8 - 15	8	148,000	999227	998793	116Z06	02Z93	15-in.	19X43	49
200 O-FG	999236	30 - 50	10 - 20	24	297,000	999230	9987					
500 O-FG	999088**	85 - 90 65 - 85 75 - 90	22 - 32*** 11 - 18† 14 - 22‡	29	735,000	999094	999095	999089	999090	21-in.	998825*	51

* Requires extension coupling (998838 for No. 200; 998839 for No. 250, 300, and 500).

** Assembly includes captive connecting nut (999101) and retaining ring (999102).

*** Natural Gas

† Propane

‡ FG-2

NOTE: For gas consumption information on the welding and heating heads, see Operating Data Section, Note 2.

Table 5 - 1565 & 1502 Series Acetylene Cutting Nozzles (CW-500)

Nozzle		Steel Thickness,		Gas Pressure, psig		Gas Consumption, ft ³ /hr		Cleaning Drill Size					
Size	Part No.	in.	mm	Oxygen	Acetylene	Oxygen	Acetylene	Preheat	Cutting				
1565 Series (Low Acetylene Consumption)													
1/8"	639182	1/8	3	42	5 - 8	15 - 20	5 - 9	73	78				
1/4"	639263	1/4	6			35 - 40			69				
1/2"	639264	1/2	13			55 - 65			65				
3/4"	639265	3/4	19			60 - 70			61				
1"	639266	1	25			85 - 95			54				
2"	639267	2	50			155 - 165			8 - 12	70	51		
3"	639268	3	75			215 - 230			10 - 15	69	47		
4"	639269	4	100			340 - 360			15 - 20	65	40		
6"	998742	6	150			35 - 45			8 - 10	395 - 460	20 - 25	57	39
		8	200			55 - 65				545 - 625	30 - 35		
1502 Series (Medium Preheat)													
1/4"	08Z67	1/4	6	25 - 30	5 - 8	35 - 45	6 - 8	69	68				
1/2"	15Z17	1/2	13	35 - 40		65 - 75	8 - 10	66	60				
1-1/2"	15Z18	3/4	19	35 - 40	5 - 8	120 - 135	14 - 16	65	53				
		1	25	40 - 45		130 - 140	14 - 16						
4"	15Z19	2	50	30 - 35	6 - 9	185 - 210	16 - 20	61	46				
		3	75	40 - 45		205 - 255	16 - 20						
		4	100	45 - 50		235 - 285	19 - 22						
8"	15Z20	6	150	35 - 45	8 - 10	395 - 460	20 - 25	57	39				
		8	200	55 - 65		545 - 625	30 - 35						

Table 6 - 1567 & 1534 Series Fuel Gas Two-Piece Cutting Nozzles (CW-500) NOTE: Do NOT use with acetylene

Nozzle Size	Nozzle (Internal) Part No.	Sleeve (External) *			Steel Thickness		Gas Pressure, psig		Gas Consumption, ft ³ /hr			Cleaning Drill Size Cutting***
		Long	Part No. Medium	Short	in.	mm	Oxygen	Fuel Gas	Oxygen	FG-2**	Nat. Gas	
1567 Series (High Preheat)												
1/8"	639614				1/8	3		3 - 4	20 - 40	5 - 10	20 - 25	79
1/4"	639615				1/4	6		3 - 4	45 - 65	5 - 10	20 - 25	69
1/2"	639616				1/2	13		3 - 4	65 - 85	5 - 10	20 - 25	65
3/4"	639617	639322	998557	998277	3/4	19	42	3 - 4	70 - 90	5 - 10	20 - 25	61
1"	639618				1	25		4 - 5	95 - 115	5 - 10	25 - 30	54
2"	639619				2	50		4 - 5	175 - 200	8 - 15	30 - 35	51
3"	639620				3	75		6 - 7	235 - 260	8 - 15	35 - 40	47
4"	998734	14Z39	998561	114Z08	4	100	42	4 - 5	285 - 305	8 - 15	35 - 40	46
1534 Series (Medium Preheat)												
2"	14Z66				1/8	3	25 - 30		25 - 45			76
3"	14Z50	14Z38	998560	114Z07	1/4	6	30 - 35	3 - 4	45 - 65	5 - 10	15 - 20	68
4"	14Z51				1/2	13	30 - 35		70 - 90			60
6"	14Z52	14Z39	998561	114Z08	3/4	19	30 - 35	3 - 4	125 - 145	5 - 10	15 - 20	53
					1	25	35 - 40		140 - 160			
8"	14Z53	14Z39	998561	114Z08	2	50	25 - 30	4 - 5	150 - 170	8 - 15	30 - 40	46
					3	75	40 - 45		280 - 300			
					4	100	40 - 45		285 - 305			

* Long - For use with natural gas, propane, and butane.

Medium - For use with methylacetylene-propadiene (MPS) and propylene-based fuel gases where high preheat intensity is desired.

Short - For use with methylacetylene-propadiene (MPS) and propylene-based fuel gases for general purpose cutting.

** Consumption of MAPP or propane is approximately the same as FG-2.

*** Use soft-bristled brush (750F99) to clean preheat slots of internal nozzles.

GENERAL

Replacement Parts are illustrated on the following figures. When ordering replacement parts, order by part number and part name, as illustrated on the figure.

ORDERING

To assure proper operation, it is recommended that only genuine ESAB parts and products be used with this equipment. The use of non-ESAB parts may void your warranty.

Replacement parts may be ordered from your ESAB distributor or from:

ESAB Welding & Cutting Products
Attn: Customer Service Dept.
P.O. Box 100545, 411 S. Ebenezer Road
Florence, SC 29501-0545

Be sure to indicate any special shipping instructions when ordering replacement parts.

To order parts by phone, contact ESAB at 1-843-664-5540. Orders may also be faxed to 1-800-634-7548. Be sure to indicate any special shipping instructions when ordering replacement parts.

Refer to the Communication Guide located on the last page of this manual for a list of customer service phone numbers.

PARTS INFORMATION

All parts which can be replaced without breaking soldered or brazed joints are illustrated and listed below. When ordering parts, please give both part number and description (including size, where appropriate). Parts may be ordered from your welding distributor or from ESAB Welding & Cutting Products, Customer Services Department, Florence, SC.

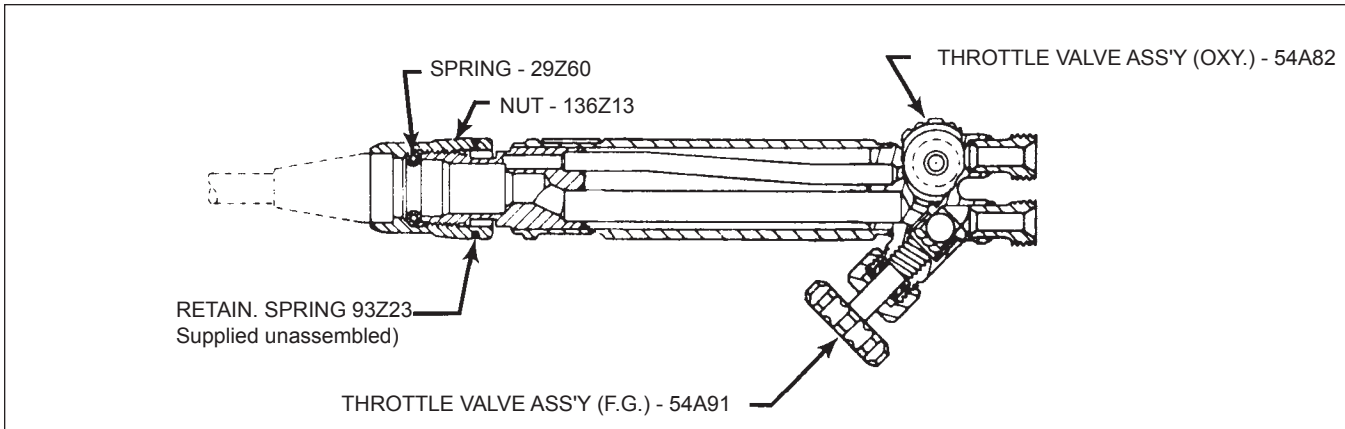

Fig. 1 - Replacement Parts - W-500 Welding Torch - P/N 999079

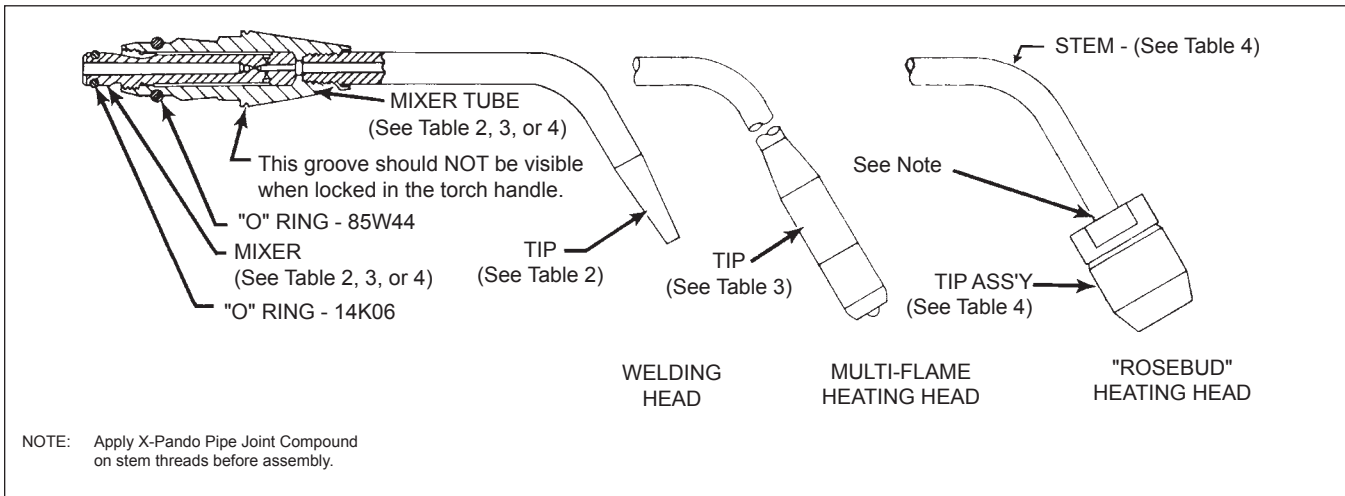

Fig. 2 - Replacement Parts - Welding and Heating Head Assemblies

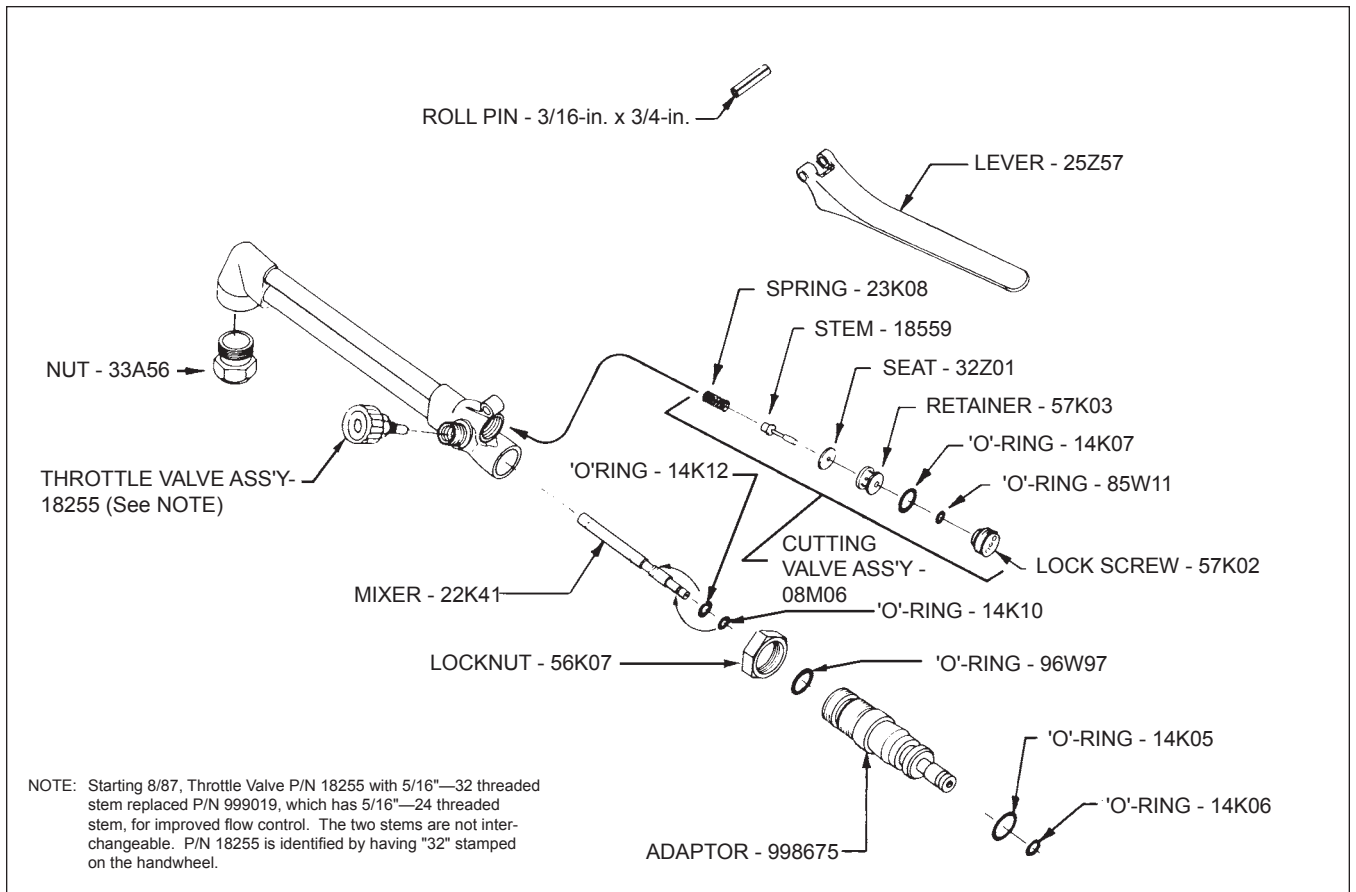

Fig. 3 - Replacement Parts - CW-500 Cutting Attachment (90-deg. Head) - 999220

**ESAB Welding & Cutting Products, Florence, SC Welding Equipment
COMMUNICATION GUIDE - CUSTOMER SERVICES**

- A. CUSTOMER SERVICE QUESTIONS:
Telephone: (800)362-7080 / Fax: (800) 634-7548 Hours: 8:00 AM to 7:00 PM EST
Order Entry Product Availability Pricing Order Information Returns
- B. ENGINEERING SERVICE:
Telephone: (843) 664-4416 / Fax : (800) 446-5693 Hours: 7:30 AM to 5:00 PM EST
Warranty Returns Authorized Repair Stations Welding Equipment Troubleshooting
- C. TECHNICAL SERVICE:
Telephone: (800) ESAB-123/ Fax: (843) 664-4452 Hours: 8:00 AM to 5:00 PM EST
Part Numbers Technical Applications Specifications Equipment Recommendations
- D. LITERATURE REQUESTS:
Telephone: (843) 664-5562 / Fax: (843) 664-5548 Hours: 7:30 AM to 4:00 PM EST
- E. WELDING EQUIPMENT REPAIRS:
Telephone: (843) 664-4487 / Fax: (843) 664-5557 Hours: 7:30 AM to 3:30 PM EST
Repair Estimates Repair Status
- F. WELDING EQUIPMENT TRAINING
Telephone: (843)664-4428 / Fax: (843) 679-5864 Hours: 7:30 AM to 4:00 PM EST
Training School Information and Registrations
- G. WELDING PROCESS ASSISTANCE:
Telephone: (800) ESAB-123 Hours: 7:30 AM to 4:00 PM EST
- H. TECHNICAL ASST. CONSUMABLES:
Telephone : (800) 933-7070 Hours: 7:30 AM to 5:00 PM EST

IF YOU DO NOT KNOW WHOM TO CALL

Telephone: (800) ESAB-123
Fax: (843) 664-4462
Hours: 7:30 AM to 5:00 PM EST
or
visit us on the web at <http://www.esabna.com>
The ESAB web site offers
Comprehensive Product Information
Material Safety Data Sheets
Warranty Registration
Instruction Literature Download Library
Distributor Locator
Global Company Information
Press Releases
Customer Feedback & Support



ESAB Welding & Cutting Products
PO Box 100545, Florence SC 29501-0545