



MADE TO WORK AS HARD AS YOU DO.

Rough work, grinding, brushing, cutting, finishing and polishing, hardly any tool is used as much as an angle grinder. Therefore, we have divided our angle grinders into three classes: compact, intermediate and full size, so you always get the right tool for the job. Metabo grinders have the latest technology and longevity. **Metabo. Work. Don't play.**





Double insulation

Double insulation protects against electric shock by creating a non-conducting barrier between the operator and the electric components inside the tool.

Metabo safety clutch

For protection against kick-back which can occur if the wheel jams.

Ergonomic design
2 "comfort" zones for superior grip.

Metabo "Quick" spannerless wheel change system

Metabo quick wheel change system allows for safe, tool-free wheel change.

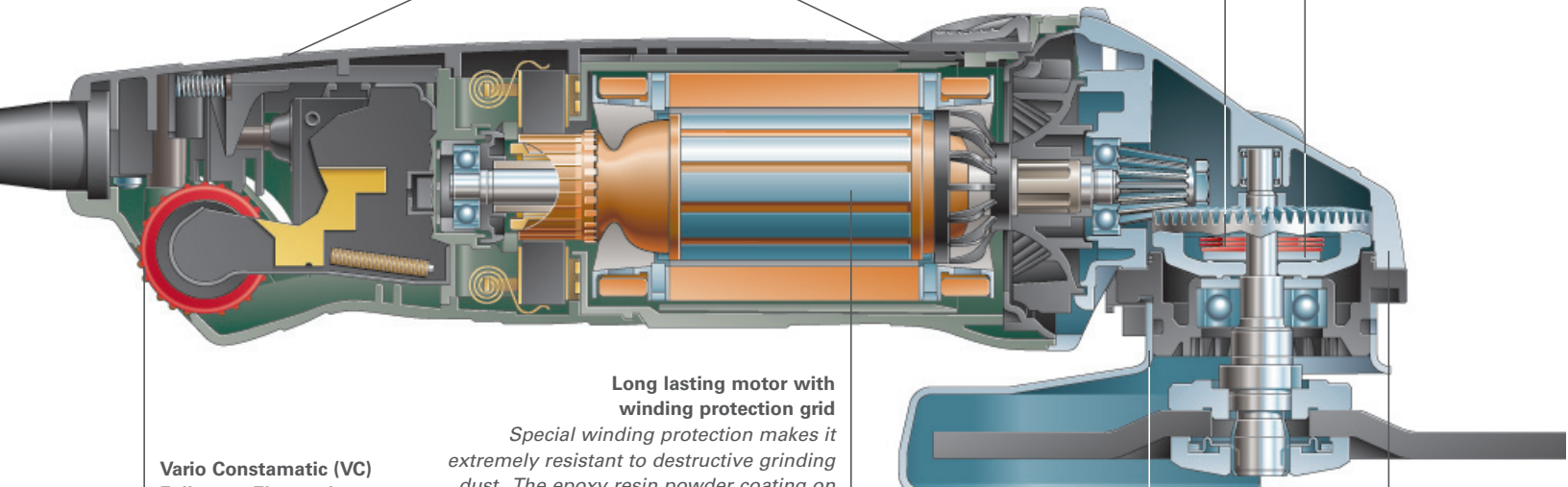

Long lasting motor with winding protection grid

Special winding protection makes it extremely resistant to destructive grinding dust. The epoxy resin powder coating on the field coil helps prevent overheating of the motor under heavy loads. Winding protection grid deflects harmful airborne debris away from armature windings thus the motor will last up to five times longer than a motor without such protection.

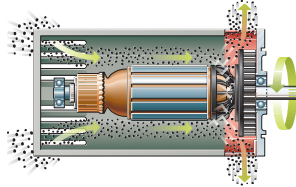

Vario Constamatic (VC) Full-wave Electronic Speed Control

The speed can be varied from the lowest speed value to the maximum. The speed remains constant under moderate load and drops under heavy load.

Tacho Constamatic (TC) Full-wave Electronic Speed Control

Vario Tacho Constamatic (VTC) Full-wave Electronic Speed Control

The speed at rated load, even under heavy operating conditions is equal to the no-load speed.

Toolless guard adjustment

Quickly change the position of the guard without using tools. Easy operation increases operator safety.

Aluminum die-cast housing

For optimum heat dissipation and superior durability.

Electronic winding temperature monitor

Warning light of a possible overload when the windings approach a harmful temperature. (WE14- models only)





Vibrattech anti-vibration handle

The Vibrattech handle is a response to the requests for the reduction of the cumulative problems associated with vibration to the hands and arms from the use of power tools. Vibration on the side handle is reduced by up to 60% compared to the current handle. The risk of "White Finger Syndrome" caused by vibration exposure over the workers lifespan is reduced considerably! (see page 57)

Twister 3 position rear handle for cutting/grinding

The Metabo twister handle turns 90 degrees in either direction, without tools.

The right grinder for every application.

Class division		Type	Page
<p>The compact class</p> <p>Maximum grinding wheel dia. 4 1/2", 5", 6"</p> <p>Its strengths: Wire brushing Cutting medium-sized profiles. Rough grinding for welding preparation. Smoothing welded seams. Grinding metal, wood, plastics (with electronics). Cutting tiles. Stone cutting, forming, polishing</p>		<p>Rated input watts 800-1400</p> <p>W6-115 49</p> <p>W8-115 Kit NEW! 49</p> <p>W8-115 49</p> <p>W8-115 Quick 49</p> <p>WP7-115 Quick 50</p> <p>WPS7-115 Quick 50</p> <p>W8-125 50</p> <p>WP7-125 Quick 51</p> <p>WPS7-125 Quick 51</p> <p>WE9-125 Quick 51</p> <p>W11-125 Quick 51</p> <p>WB11-125 Quick 52</p> <p>W11-150 Quick 52</p> <p>WB11-150 Quick 52</p> <p>WE14-125 Plus 52</p> <p>WE14-125 VS NEW! 53</p> <p>WE14-150 Quick 53</p> <p>WEP14-150 Quick 53</p>	
<p>The intermediate class</p> <p>Maximum grinding wheel dia. 5" & 6"</p> <p>Its strengths: Cutting thick profiles. Smoothing thick welded seams. Hard grinding.</p>		<p>Rated input watts 1400</p> <p>W14-125 Ergo 54</p> <p>W14-150 Ergo 54</p> <p>W14-150 Ergo (DM) 54</p>	
<p>The full size class</p> <p>Maximum grinding wheel dia. 7", 9"</p> <p>Its strengths: Cutting full material. Cutting concrete and slabs. Hard grinding.</p>		<p>Rated input watts 2300-2500</p> <p>W23-180 55</p> <p>W23-230 55</p> <p>W25-230 55</p> <p>W21-230 55</p>	



The NEW Metabo angle grinders work harder, and longer!

Extreme Dust protection:

“An *encapsulated switch, labyrinth seals with double sealing lips* on the ball bearings and *auto-stop carbon brushes with encapsulated carbon holders* protect the internals from the accumulation of grinding dust particles. Combined with the *Metabo “Long Life” motor, the winding protection grid and epoxy coated windings*, this new breed of angle grinders are virtually indestructible!”

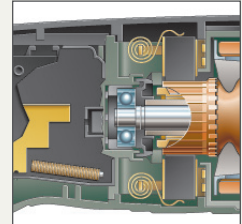

Optimum cooling:

An improved *sonically balanced fan* coupled with better venting and more efficient internal ducting channels have resulted in a **10-15% increase* in air flow** over the motor. As a result, these new grinders can work harder, longer; performance and durability are increased. (*dependent on model)

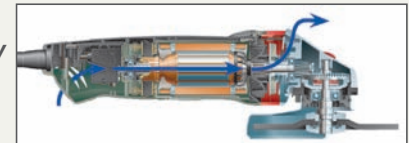

The NEW Metabo angle grinders work safely!

Optimum User protection:

The Metabo S-automatic torque limiting clutch in most models helps to protect the user from the dangerous kickback that can occur if the tool jams or gets caught. By absorbing the sudden reaction torque, the Metabo S-automatic torque limiting clutch allows the user to control and remove the tool from whatever is causing the binding.

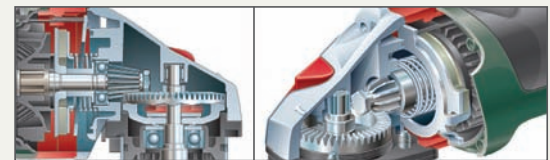

Excellent Ergonomics:

Metabo small angle grinders offer the widest selection of switch type and grip style; top switch tools with dual grip zones that perfectly fit the hand and the exclusive ‘racket grip’ for added safety; paddle switch tools with locking or non-locking switches. Metabo medium and large angle grinders offer locking or non-switches and the ‘Twister’ handle rotates 90 degrees left or right, to maintain the perfect grip in all applications.



W6-115
4 1/2" Angle Grinder

W8-115 Kit
4 1/2" Angle Grinder

W8-115
4 1/2" Angle Grinder

W8-115 Quick
4 1/2" Angle Grinder

NEW

Model # Order #	W6-115 606111420	W8-115 Kit 600259850	W8-115 600259420	W8-115 Quick 600264420
Long lasting motor		●	●	●
Quick wheel change system				●
Switch with lock on capability	●	●	●	●
AC/DC capability		●	●	●
Spindle lock	●	●	●	●
Low profile aluminum die-cast gear housing	●	●	●	●
Toolless guard adjustment		●	●	●
2-position side handle	●	●	●	●
Metabo slip clutch		●	●	●
Auto-stop carbon brushes		●	●	●
Winding protection grid		●	●	●
Maximum Torque	16 inch lbs.	19.5 inch lbs.	19.5 inch lbs. Also available in 220V	19.5 inch lbs. Also available in 220V
Maximum wheel diameter	4 1/2"	4 1/2"	4 1/2"	4 1/2"
No-load speed (RPM)	11000	10000	10000	10000
Amps	6.0	8.0	8.0	8.0
Rated input watts	650	800	800	800
Arbor size	7/8"	7/8"	7/8"	7/8"
Spindle thread	5/8"-11	5/8"-11	5/8"-11	5/8"-11
Tool weight	4.5 lbs.	5.4 lbs.	5.4 lbs.	5.4 lbs.
Shipping weight	6.0 lbs.	9.6 lbs.	6.3 lbs.	6.2 lbs.
Length	11"	11 3/4"	11 3/4"	11 3/4"
Carrying case	656304000 or 625445000 (optional)	625445000 (standard)	344453610 (optional)	344453610 (optional)

Standard Equipment:	W6-115	W8-115 Kit	W8-115	W8-115 Quick
	Side Handle (314000540)	Side Handle (314000970)	Side Handle (314000970)	Side Handle (314000970)
	Wheel Guard (316040740)	Wheel Guard (316035700)	Wheel Guard (339202990)	Wheel Guard (339202990)
	Inner Flange (341031290)	Inner Flange (341031290)	Inner Flange (341031290)	Inner Flange (341031290)
	Face Spanner (623934000)	Face Spanner (623934000)	Face Spanner (623934000)	Outer Nut (316023840)
	Outer Nut (341101480)	Outer Nut (341101480)	Outer Nut (341101480)	
		4 1/2" x .080 diamond blade		

Optional Equipment:	W6-115	W8-115 Kit	W8-115	W8-115 Quick
	Type 1 Cut-off Wheel Guard (631189000)	Type 1 Cut-off Wheel Guard (630366000)	Type 1 Cut-off Wheel Guard (630366000)	Type 1 Cut-off Wheel Guard (630366000)
		'Dust Director' Guard (655270000)	'Dust Director' Guard (655270000)	'Dust Director' Guard (655270000)

(See page 120 for 220V tools)



WP7-115 Quick
4 1/2" Angle Grinder



WPS7-115 Quick
4 1/2" Angle Grinder



W8-125
4 1/2"/5" Angle Grinder

Model # Order #	WP7-115 Quick 606210420	WPS7-115 Quick 606208420	W8-125 600263420
Long lasting motor	●	●	●
Quick wheel change system	●	●	
Switch with lock on capability	●		●
AC/DC capability			●
Spindle lock	●	●	●
Low profile aluminum die-cast gear housing	●	●	●
Toolless guard adjustment	●	●	●
2-position side handle	●	●	●
Metabo slip clutch	●	●	●
Auto-stop carbon brushes	●	●	●
Winding protection grid	●	●	●
Maximum Torque	19.5 inch lbs.	19.5 inch lbs. Also available in 220V	19.5 inch lbs Also available in 220V
Maximum wheel diameter	4 1/2"	4 1/2"	5"
No-load speed (RPM)	10000	10000	10000
Amps	8.0	8.0	8.0
Rated input watts	900	900	800
Arbor size	7/8"	7/8"	7/8"
Spindle thread	5/8"-11	5/8"-11	5/8"-11
Tool weight	5.0 lbs.	5.0 lbs.	5.4 lbs.
Shipping weight	6.0 lbs.	6.0 lbs.	6.2 lbs.
Length	12 1/2"	12 1/2"	11 3/4"
Carrying case	625445000 (optional)	625445000 (optional)	344453610 (optional)

Standard Equipment:	WP7-115 Quick	WPS7-115 Quick	W8-125
	Side Handle (314000970)	Side Handle (314000970)	Side Handle (314000970)
	Wheel Guard (316035700)	Wheel Guard (316035700)	Wheel Guard (339203010)
	Inner Flange (341031290)	Inner Flange (341031290)	Inner Flange (341031290)
	Outer Nut (316023840)	Outer Nut (316023840)	Face Spanner (623934000) Outer Nut (341101480)

Optional Equipment:	WP7-115 Quick	WPS7-115 Quick	W8-125
	Type 1 Cut-off Wheel Guard (655139000)	Type 1 Cut-off Wheel Guard (655139000)	Type 1 Cut-off Wheel Guard (630367000)
	'Dust Director' Guard (655254000)	'Dust Director' Guard (655254000)	'Dust Director' Guard (655270000)

(See page 120 for 220V tools)



WP7-125 Quick
5" Angle Grinder

WPS7-125 Quick
5" Angle Grinder

WE9-125 Quick
4 1/2"/5" Angle Grinder

W11-125 Quick
4 1/2"/5" Angle Grinder

Model # Order #	WP7-125 Quick 606211420	WPS7-125 Quick 606209420	WE9-125 Quick 600269420	W11-125 Quick 600270420
Vario constamatic (VC) electronics			●	
Long lasting motor	●	●	●	●
Quick wheel change system	●	●	●	●
Switch with lock on capability	●		●	●
AC/DC capability			●	●
Spindle lock	●	●	●	●
Low profile aluminum die-cast gear housing	●	●	●	●
Toolless guard adjustment	●	●	●	●
2-position side handle	●	●	●	●
Metabo slip clutch	●	●	●	●
Auto-stop carbon brushes	●	●	●	●
Winding protection grid	●	●	●	●
Maximum Torque	21 inch lbs.	21 inch lbs	22 inch lbs. Also available in 220V	26.9 inch lbs.. Also available in 220V
Maximum wheel diameter	5"	5"	5"	5"
No-load speed (RPM)	9000	9000	3000-10000	10000
Amps	8.0	8.0	8.5	9.6
Rated input watts	900	900	950	1100
Arbor size	7/8"	7/8"	7/8"	7/8"
Spindle thread	5/8"-11	5/8"-11	5/8"-11	5/8"-11
Tool weight	5.1 lbs.	5.1 lbs.	5.4 lbs.	5.8 lbs.
Shipping weight	6.2 lbs.	6.2 lbs.	6.2 lbs.	6.8 lbs.
Length	12 1/2"	12 1/2"	11 3/4"	12 1/4"
Carrying case	625445000 (optional)	625445000 (optional)	344453610 (optional)	344453610 (optional)
Standard Equipment:	Side Handle (314000970) Wheel Guard (316035710) Inner Flange (341031290) Outer Nut (316023840)	Side Handle (314000970) Wheel Guard (316035710) Inner Flange (341031290) Outer Nut (316023840)	Side Handle (314000970) Wheel Guard (339203010) Inner Flange (341031290) Outer Nut (316023840)	Side Handle (314000970) Wheel Guard (339203010) Inner Flange (341031290) Outer Nut (316023840)
Optional Equipment:	Type 1 Cut-off Wheel Guard (655139000) 'Dust Director' Guard (655254000)	Type 1 Cut-off Wheel Guard (655139000) 'Dust Director' Guard (655254000)	Type 1 Cut-off Wheel Guard (630367000) 'Dust Director' Guard (655270000)	Type 1 Cut-off Wheel Guard (630367000) 'Dust Director' Guard (655270000)

(See page 120 for 220V tools)



WB11-125 Quick
4 1/2"/5" Angle Grinder

W11-150 Quick
5"/6" Angle Grinder

WB11-150 Quick
5"/6" Angle Grinder

WE14-125 Plus
4 1/2"/5" Angle Grinder

Model # Order #	WB11-125 Quick 600274420	W11-150 Quick 600271420	WB11-150 Quick 600276420	WE14-125 Plus 600281420
Vario tacho constamatic (VTC) electronics				●
Long lasting motor	●	●	●	●
Quick wheel change system	●	●	●	●
Metabo disc brake	●		●	
Switch with lock on capability	●	●	●	●
AC/DC capability	●	●	●	●
Spindle lock	●	●	●	●
Low profile aluminum die-cast gear housing	●	●	●	●
Toolless guard adjustment	●	●	●	●
2-position side handle	●	●	●	●
Metabo slip clutch	●	●	●	●
Auto-stop carbon brushes	●	●	●	●
Winding protection grid	●	●	●	●
Electronic soft start feature				●
Electronic speed stabilization				●
Maximum Torque	26.9 inch lbs. Also available in 220V	29.2 inch lbs Also available in 220V	29.2 inch lbs. Also available in 220V	29.2 inch lbs. Also available in 220V
Maximum wheel diameter	5"	6"	6"	5"
No-load speed (RPM)	10000	9000	9000	7000-10500
Amps	9.6	9.6	9.6	12.2
Rated input watts	1100	1100	1100	1400
Arbor size	7/8"	7/8"	7/8"	7/8"
Spindle thread	M14-1.5	5/8"-11	M14-1.5	5/8"-11
Tool weight	6.0 lbs.	6.0 lbs.	6.25 lbs.	6.2 lbs.
Shipping weight	7.0 lbs.	7.0 lbs.	7.25 lbs.	7.2 lbs.
Length	13"	12.25"	13"	12.25"
Carrying case	656304000 (optional)	656304000 (optional)	656304000 (optional)	344453610 (optional)
Standard Equipment:	Side Handle (314000970) Wheel Guard (339203010) Inner Flange (341031290) Outer Nut (316042740)	Side Handle (314000970) Wheel Guard (339203020) Inner Flange (341031290) Outer Nut (316023840)	Side Handle (314000970) Wheel Guard (339203020) Inner Flange (341031290) Outer Nut (316042740)	Side Handle (314000970) Wheel Guard (339203010) Inner Flange (341031290) Outer Nut (316023840)
Optional Equipment:	Type 1 Cut-off Wheel Guard (630367000) 'Dust Director' Guard (655270000)	Type 1 Cut-off Wheel Guard (630368000) 'Dust Director' Guard (655270000)	Type 1 Cut-off Wheel Guard (630368000) 'Dust Director' Guard (655270000)	Type 1 Cut-off Wheel Guard (630367000) 'Dust Director' Guard (655270000)

(See page 120 for 220V tools)



WE14-125 VS
Electronic Variable Speed
4 1/2"/ 5" Angle Grinder



WE14-150 Quick
5"/ 6" Angle Grinder



WEP14-150 Quick "Deadman"
Excalibur– Electronic 6" Angle
Grinder/Cut-off Machine with
non-locking paddle switch

NEW

Model # Order #	WE14-125 VS 600292420	WE14-150 Quick 600160420	WEP14-150 Quick 601452420
Vario tacho constamatic (VTC) electronics	●		
Tacho constamatic (TC) electronics		●	●
Long lasting motor	●	●	●
Quick wheel change system		●	●
Switch with lock on capability	●	●	
AC/DC capability	●	●	
Current interruption protection	●	●	●
Spindle lock	●	●	●
Low profile aluminum die-cast gear housing	●	●	●
Variable speed controlled by adjusting dial	●		
Toolless guard adjustment	●	●	●
2-position side handle	●	●	●
Electronic winding temperature monitor with LED display		●	●
Metabo slip clutch	●	●	●
Auto-stop carbon brushes	●	●	●
Winding protection grid	●	●	●
Electronic soft start feature	●	●	●
Electronic speed stabilization	●	●	●
Maximum Torque	29.2 inch lbs.	31 inch lbs. Also available in 220V	31 inch lbs.
Maximum wheel diameter	5"	6"	6"
No-load speed (RPM)	2800-10500	9000	9000
Amps	12.2	12.2	12.0
Rated input watts	1400	1400	1400
Arbor size	7/8"	7/8"	7/8"
Spindle thread	5/8"-11	5/8"-11	5/8"-11
Tool weight	6.2 lbs.	6.3 lbs.	5.6 lbs.
Shipping weight	7.2 lbs.	7.3 lbs.	7.0 lbs.
Length	12.25"	12.25"	12"
Carrying case	344453610 (optional)	656304000 (optional)	656304000 (optional)
Standard Equipment:	Side handle (314000540) Wheel guard (339203010) Inner flange (341031290) Outer nut (341104800) Spanner Wrench (623934000)	Side handle (314000970) Wheel guard (339203020) Type 27 Inner flange (341031850) Outer nut (316023840) Flange Kit (316037200)	Side handle (314000970) Wheel guard (316035720) Type 27 Inner flange (341031850) Outer nut (316023840) Flange Kit (316037200)
Optional Equipment:	Type 1 Cut-off Wheel Guard (630368000) 'Dust Director' Guard (655270000)	Type 1 Cut-off Wheel Guard (630368000)	Type 1 Cut-off Wheel Guard (655140000)



W14-125 Ergo
5" Angle Grinder



W14-150 Ergo
6" Angle Grinder



W14-150 Ergo "Deadman"
6" Angle Grinder with
non-locking paddle type switch

Model # Order #	W14-125 Ergo 606250420	W14-150 Ergo 606251420	W14-150 Ergo 606251440
Maximum grinding wheel diameter	5"	6"	6"
Long lasting motor	●	●	●
Spindle lock	●	●	●
3-position side handle	●	●	●
Twister 3-position rear handle for cutting/grinding	●	●	●
Toolless guard adjustment	●	●	●
Winding Protection Grid	●	●	●
Safety lock to prevent the accidental switching on of the tool	●	●	●
Auto-stop carbon brushes	●	●	●
Suitable for occasional DC use	●	●	●
Maximum Torque	44 inch lbs.	44 inch lbs. Also available in 220V	44 inch lbs.
Maximum wheel diameter	5"	6"	6"
No-load speed (RPM)	9700	9700	9700
Amps	12.0	12.0	12.0
Rated input watts	1400	1400	1400
Arbor size	7/8"	7/8"	7/8"
Spindle thread	5/8"-11	5/8"-11	5/8"-11
Tool weight	8.1 lbs.	8.2 lbs.	8.2 lbs.
Shipping weight	10.1 lbs.	10.2 lbs.	10.2 lbs.
Length	15 1/2"	16"	16"
Carrying case	623874000 (optional)	623874000 (optional)	623874000 (optional)
Standard Equipment:	Side handle (314000970) Wheel guard (316035710) Inner flange (341031290) Outer nut (341101480) Face spanner (623934000)	Side handle (314000970) Wheel guard (316035720) Inner flange (341031290) Outer nut (341101480) Face spanner (623934000)	Side handle (314000970) Wheel guard (316035720) Inner flange (341031290) Outer nut (341101480) Face spanner (623934000)

Optional Equipment:	Type 1 Cut-off Wheel Guard (655139000)	Type 1 Cut-off Wheel Guard (655140000)	Type 1 Cut-off Wheel Guard (655140000)
---------------------	--	--	--

(See page 120 for 220V tools)



W23-180*
7" Angle Grinder



W23-230
9" Angle Grinder



W25-230
9" Angle Grinder



W21-230
9" Angle Sander

Model #	W23-180	W23-230	W25-230	W21-230
Order #	606410420	606415420	606425420	606405470
Order # (non-locking deadman switch)	US606410760	US606415760	n/a	n/a
Maximum grinding wheel diameter	7"	9"	9"	9"
Long lasting motor	●	●	●	●
Spindle lock	●	●	●	●
3 position side handle	●	●	●	●
Twister 3 position rear handle for cutting/grinding	●	●	●	●
Toolless guard adjustment	●	●	●	●
Winding Protection Grid	●	●	●	●
Safety lock to prevent the accidental switching on of the tool	●	●	●	●
Auto-stop carbon brushes	●	●	●	●
Suitable for occasional DC use	●	●	●	●
Maximum Torque	124 inch lbs. Also available in 220V	150 inch lbs. Also available in 220V	159 inch lbs. Also available in 220V	150 inch lbs.
Maximum wheel diameter	7"	9"	9"	9"
No-load speed (RPM)	8500	6600	6600	6000
Amps	15.0	15.0	15.0	15.0
Rated input watts	2300	2300	2500	2100
Arbor size	7/8"	7/8"	7/8"	7/8"
Spindle thread	5/8"-11	5/8"-11	5/8"-11	5/8"-11
Tool weight	13.3 lbs.	13.6 lbs.	14 lbs.	12.3 lbs.
Shipping weight	17 lbs.	17.3 lbs.	19 lbs.	16 lbs.
Length	18"	18"	18"	18"
Carrying case	623874000 (optional)	623874000 (optional)	623874000 (optional)	623874000 (optional)

Standard Equipment:	Side handle (314000960) Wheel guard (316025890)	Side handle (314000960) Wheel guard (316025880)	Side handle (314000960) Wheel guard (316025880)	Side handle (314000960)
---------------------	--	--	--	-------------------------

Optional Equipment:

For mounting Type 1 and Type 27 non-hubbed wheels



655038000 Adapter kit to mount diamond blades on 7" - 9" grinders



655039000 Adapter kit to mount 7" - 9" Type 27 wheels w/o hub.
655052000 replacement nut

Dustless 7" Convertable Shroud



655154000 Dustless 7" Convertable Shroud
For concrete surface prep using 7" diamond cup wheels on W23-180, W23-230, W25-230 or W21-230.

Note: Use as an angle grinder requires optional wheel guard:

(Use with Type 27 or Type 1 wheels)

7" 316025890

9" 316025880

(Use with Type 11 cup wheels)

5" 655174000

6" 655178000

(See page 120 for 220V tools)